



Yamaha Releases a 5-model Amplifier Series Optimal for Installation Use

XP is the Yamaha's new 5-model power amplifier series for installation that achieves high sound quality and high cost performance. The power amplifier featuring high power, high quality, high reliability and high stability matches various installation sound systems and provides superior acoustic features even in live performance applications.

POWER AMPLIFIER



*except XP3500, XP2500, XP1000

XP7000	700W+700W (8Ω, 20Hz-20kHz), compatible with 70V lines (STEREO)
XP5000	500W+500W (8Ω, 20Hz-20kHz)
XP3500	350W+350W (8Ω, 20Hz-20kHz), compatible with 100V lines (BRIDGE)
XP2500	250W+250W (8Ω, 20Hz-20kHz)
XP1000	110W+110W (8Ω, 20Hz-20kHz)

These figures are based on US120V specifications. See the specifications for details.



XP7000 Front Panel



XP7000 Rear Panel

XP Series Key Features

- 5-model lineup ranging from 700W* output to 100W* output *(STEREO 8 ohms).
- High sound quality equivalent to upper-class models with parts and emphasizing on superior sound.
- While realizing a design that ensures high sound quality, efficiency has been planned down to the finest details for full achievement of both high-definition sound and superior value.
- Yamaha's exclusive state-of-the-art high-efficiency amplifier driving technology EEEngine installed.
- A gain switch that can be changed to +4dBu / 26dB / 32dB has been installed on the rear panel for compatibility with a wide variety of input levels.

- Light weight and compact design of 2U size for installation in any location
- Monitor and remote terminals for monitoring and control from a remote location
- High-accuracy 1dB-step detented attenuator
- Various terminals and features suitable for professional use
- Special high-pass filter that enables change of cut-off frequency
- Equipped with various protection circuits, indicators and stepless low-noise fans
- Best matches with the digital mixing engine DME64N/24N and Installation series speakers

Lineup of 5 models ranging from 700W* to 100W* for use in any application *STEREO 8 ohms

The newly developed XP series consists of 5 models with different outputs ranging from 700W (STEREO 8) to 100W (STEREO 8). Ideal amplifier can be selected according to the scale and application by combining the model with finely set output. The series is designed for flexibility and versatility. It offers 3 modes: STEREO mode for driving 2-channel sources independently, PARALLEL mode for driving monaural sources using 2 channels and BRIDGE mode for high-powered driving of 2 internal amplifiers as a single monaural amplifier. The series also uses lead-free parts and is environmentally friendly.

Excellent sound quality realized by careful selection of parts, design emphasizing on sound quality and vibration tolerance

Superior sound quality equivalent to upper-class models has been realized by circuit design and careful selection of parts focusing on sound quality, and the inheritance of vibration tolerance developed for PC-1N. The series features tight low tones, full and rich high tones and abundant, stable mid-tones. Especially, the series features high resolution for spoken words and vocals.

Provides excellent value while prioritizing sound quality

With top priority placed on sound quality for all audio-related parts, efficiency was emphasized from the development stage to deliver maximum value. This helps the series provide great sound performance that is one level above similarly priced models.

Yamaha's exclusive state-of-the-art high-efficiency amplifier driving technology EEEngine installed

The XP series adopts a newly designed switching regulator that delivers the ideal power supply to the amplifier. It ensures a more stable and balanced supply of voltage and current, and eliminates fluctuations in output level. The



series also realizes clear and high sound quality equivalent to class AB and lower power consumption equivalent to class D. Low power consumption also contributes to reduction of generated heat as well as a more compact chassis, lighter weight and improved reliability. EEEngine cuts power consumption by a full 50% in comparison with conventional power amplifiers, yet without the slightest sacrifice in sound quality.

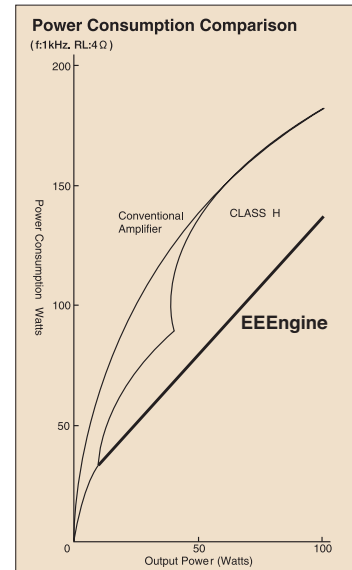

Light weight and compact design of 2U size for installation in any location

Including EEEngine, various state-of-the-art features and know-how were adopted to realize large output and high sound quality. At the same time, Yamaha succeeded in a remarkably compact and light-weight design. All 5 models are the same 2U size. XP7000 and XP5000 utilize switching power supply for high output despite the compact size. The light-weight design also brings advantage for live performance use.

Various terminals and features suitable for installation

The series is equipped with various input and output terminals suitable for professional sound control including XLR and Euro-block input terminals and Speakon and 5-way binding post output terminals. XP7000 is compatible with 70V lines (STEREO) and XP3500 is compatible with 100V lines (BRIDGE) to enable high-impedance connections capable of driving multiple speakers. The series is optimal for medium-scale facilities including churches, halls and banquet rooms as well as small-scale facilities including conference rooms and restaurants. Other than for use in such facilities, the XP series also realizes excellent performance as power amplifiers for events, exhibitions and concerts.

XP7000 Block Diagram

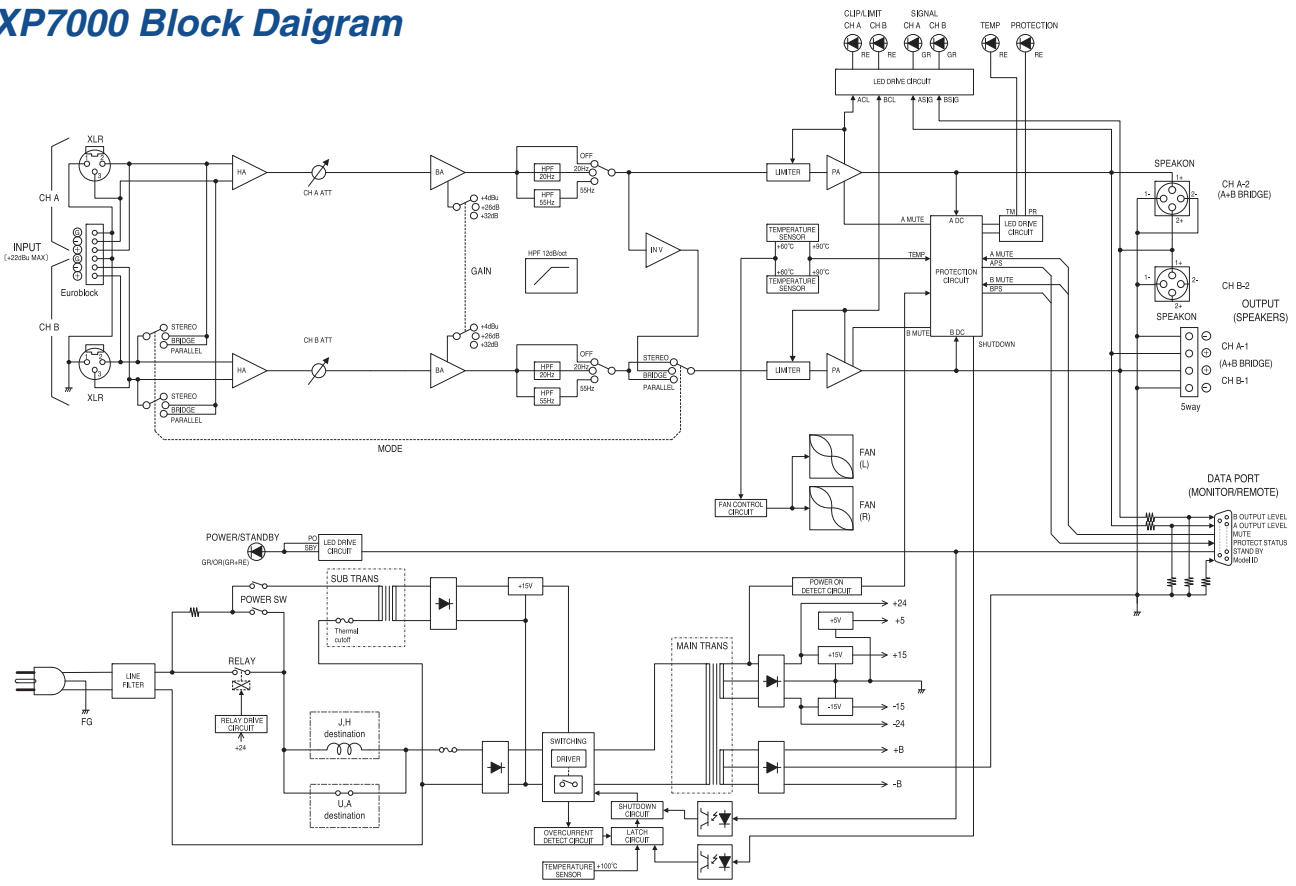

XP3500 Block Diagram

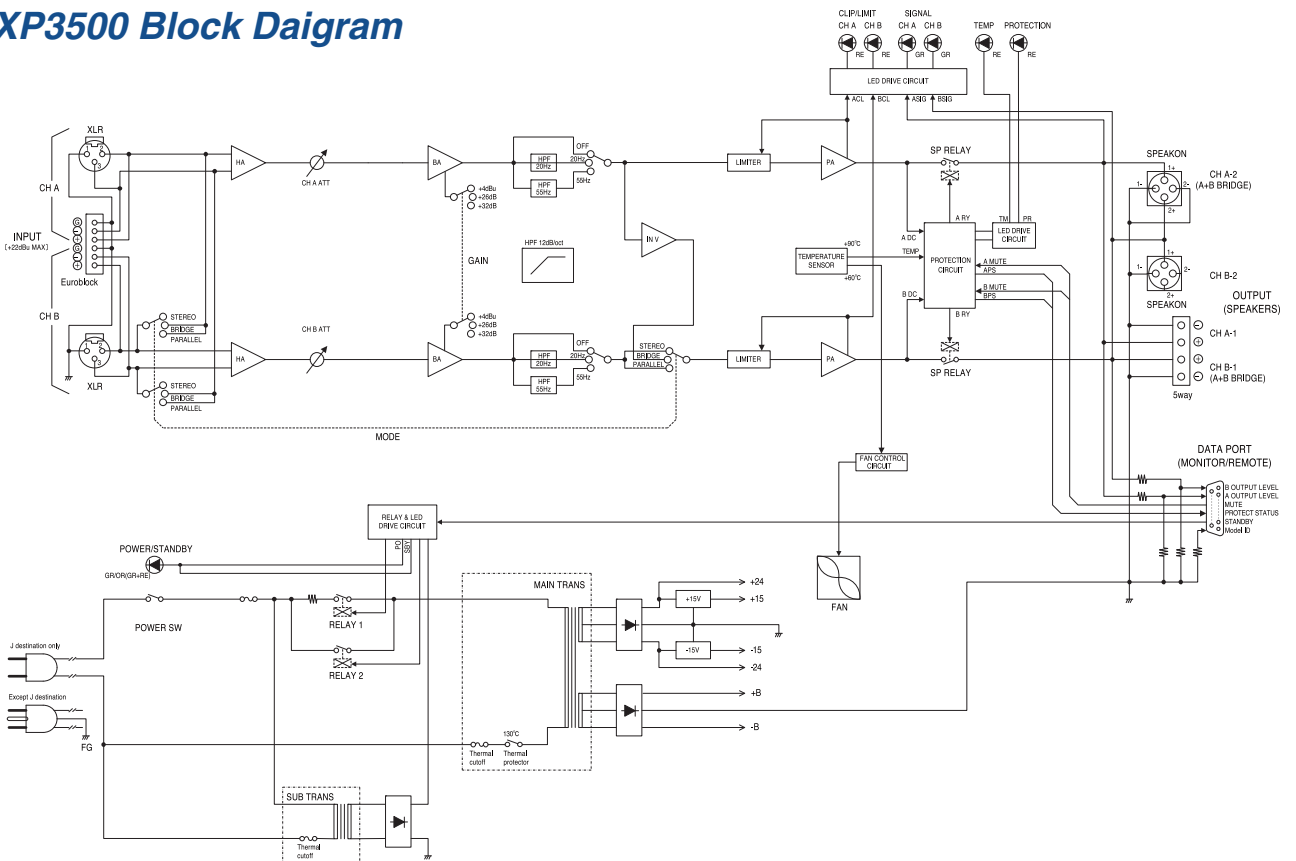

Monitor / Remote terminals enabling remote monitoring and control

The series is equipped with monitor / remote terminals for monitoring the protection status and output levels, which are crucial for power amplifiers, as well as remote operation of mute and standby from a remote location.

High-accuracy 1dB-step detented attenuator and high-pass filter for switching the cut-off frequency

The attenuator detented in 1dB-step is provided for easy and accurate settings. The series is also equipped with a high-pass filter to cut unwanted low tones. Cut-off frequency points can be selected from 20Hz and 55Hz when constructing a subwoofer system.

Various protection circuits, indicators and stepless low-noise fans

The series is equipped with various protection circuits including a circuit for detecting power-on/off, output protection circuit and DC detection circuit. Various indicators display the status of the protection system. Indicators include PROTECTION indicator, TEMP indicator that shows overheating of the heat sink, POWER/STANDBY indicator that shows the power status, as well as SIGNAL and CLIP indicators for each channel. Stepless low- noise fans that efficiently protects the unit from overheating promises high stability.

Best matches with digital mixing engine DME64N/24N and Installation series speakers

The series works significantly well with DSP box DME64N and DME24N capable of programming various types of sound processing for installation sound via GUI, as well as the Yamaha installation loudspeakers lineup.

Specification

Model		XP7000	XP5000	XP3500	XP2500	XP1000		
Output Power	1kHz	8Ω/STEREO	750W+750W	525W+525W	390W+390W	275W+275W	135W+135W	
	THD+N=0.1%	4Ω/STEREO	1100W+1100W	750W+750W	590W+590W	390W+390W	165W+165W	
		8Ω/BRIDGE	2200W	1500W	1180W	780W	330W	
	20Hz - 20kHz	8Ω/STEREO	700W+700W	500W+500W	350W+350W	250W+250W	110W+110W(US) 100W+100W	
		THD+N=0.1%	4Ω/STEREO	950W+950W	700W+700W	450W+450W 435W+435W(EU)	300W+300W 295W+295W(EU)	125W+125W(US) 115W+115W(EU) 110W+110W(A)
			70V/STEREO RL=8Ω	625W+625W	-	-	-	-
		8Ω/BRIDGE	1900W	1400W	900W, 870W(EU)	600W, 590W(EU)	250W(US), 230(EU), 220W(A)	
	100V/BRIDGE RL=16Ω	-	-	625W	-	-		
1kHz	2Ω/STEREO	1600W+1600W	1300W+1300W	1000W+1000W	650W+650W	250W+250W		
	20mS nonclip	4Ω/BRIDGE	3200W	2600W	2000W	1300W	500W	
S/N Ratio	20Hz-20kHz	104dB	103dB	102dB	100dB	96dB		
Idle Power Consumption	35W	35W	35W	30W	25W	20W		
1/8 Power Consumption (4Ω/Pink noise)		650W	500W	450W	320W	170W		
Power Bandwidth	(half power THD+N=0.5%)	10Hz-40kHz						
THD+N	20Hz - 20kHz, half power	0.1%						
Intermodulation Distortion	60Hz: 7kHz, 4:1, half power	0.1%						
Frequency Response	RL=8Ω, P ₀ =1W, HPF=OFF	MAX 0dB, TYP 0dB, MIN -1dB fs=20H-50kHz						
Channel Separation	Half power RL=8Ω 1kHz ATT. Max input 600Ω shunt	70dB						
Residual Noise Att. min	20Hz-20kHz (DIN AUDIO)	-70dBu						
Damping Factor	8Ω, f=1kHz	350(XP7000, XP5000) / 200(XP3500, XP2500, XP1000)						
Voltage Gain	ATT. max	32dB or 26dB or +4dBu input sensitivity by select switch						
Input	Att.max	+4dBu 26dB 36dB	+4dBu 26dB 36dB	+4dBu 26dB 36dB	+4dBu 26dB 36dB	+4dBu 26dB 36dB		
Sensitivity	Rated Power 8Ω	Input Sensitivity(dBu)	+4 +13.7 +7.7	+4 +12.2 +6.2	+4 +10.7 +4.7	+4 +9.2 +3.2	+4 +5.2 -0.8	
Maximum Input Voltage		+22dBu						
Input Impedance		20kΩ(balance) 10kΩ(unbalance)						
Controls	Front panel	POWER switch(push on/push off), attenuator(31position) x 2						
	Rear panel	MODE switch(STEREO/BRIDGE/PARALLEL) x 1, HPF switch (20Hz/55Hz/OFF 12dB/oct) x 2, GAIN SELECT switch(32dB/26dB/+4dBu) x 1						
Connectors	Input	XLR-3-31 type/ch, Euroblock connector(balance)/ch						
	Output	SPEAKON/ch, 5way binding post x 1						
	MONITOR/REMOTE	Dsub15P x 1						
Indicators		POWER/STANDBY x 1(Green/Orange), SIGNAL x 2(Green), CLIP/LIMIT x 2(Red), PROTECTION x 1(Red), TEMP x 1(Red) heatsink temp ≥ 85°C						
Load Protection		POWER switch on/off mute, DC-fault:power supply shutdown/do not return automatically.(XP7000, 5000), output relay off/return automatically.(XP3500,2500,1000) clip limiting :THD ≥ 0.5%						
Amplifier Protection		thermal: cut the output(heatsink temp ≥ 90°C) do not return automatically. VI limiter(RL ≤ 1Ω): Limit the output						
Power supply protection		thermal: power supply shutdown(heatsink temp ≥ 100°C) do not return automatically.(XP7000,5000), power supply shutdown(transformer temp ≥ 130°C)return automatically.(XP3500,2500,1000)						
Cooling		Variable-speed fan: x 1(XP3500, 2500, 1000), x 2(XP7000, 5000) (Fan stop at heatsink temp ≤ 55°C)						
Power Requirements		UC: 120V/60Hz, EU: 230V/50Hz, A: 240V/50Hz						
Dimensions (W x H x D)		480 x 88 x 456 mm (18-7/8" x 3-7/16" x 17-15/16")						
Weight		14kg (30.9 lbs.)	14kg (30.9 lbs.)	15kg (33.1 lbs.)	14kg (30.9 lbs.)	12kg (26.5 lbs.)		

1 0dB=0.775V Half power=1/2 power output level * Specifications and appearance subject to change without notice.

UC : US & Canadian Models EU : European Models A : Australian Models



CREATING 'KANDO' TOGETHER
'KANDO' ... Inspiring the Heart and Spirit.

RPA05-3



P10018218

Printed in Japan

YAMAHA Web Site

<http://www.yamahaproaudio.com>



This document is printed on chlorine-free (ECF) paper with soy ink.